

TIANJIN K.R.S VALVES CO., LTD.

LEAD VALVE SCIENCE AND
TECHNOLOGY 引领阀门科技

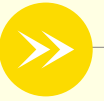

其它阀门系列 Other Valves Series





隔膜阀 G41J型

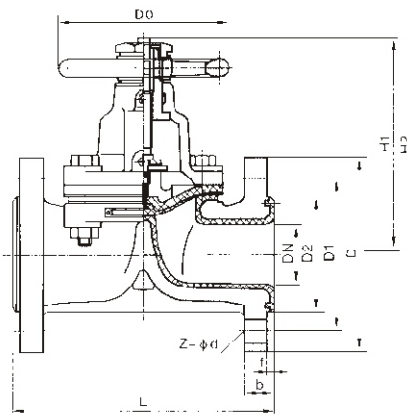

GG41Fx型手动隔膜阀(堰式)

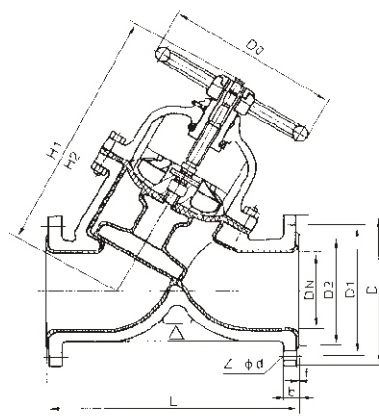

GG45Fx型手动隔膜阀(直流式)

产品执行标准 Production enforce standard

产品规范 Product Specification	设计规范 Design Spec	结构长度 Face to Face	连接法兰 Flange End	试验与检验 Test & Check	产品标识 Marking	供货单位 Supply
	GB/T12239	GB/T12221	JB/79,JB/T79	GB/T13927	GB/T12220	JB/T 7928

主要零件材料 Material for main parts

序号 Part name	灰铸铁 Cast Iron		铸钢		不锈钢耐酸铸钢		超低碳不锈钢耐酸铸钢	
	Z	C	P	R	PL	RL		
1 阀体/阀盖Body/bonnet	HT250	WCB	CF18	CF8M	CF3	CF3M		
2 阀瓣/阀杆Disc/stem	35	1Cr13	1Cr18Ni9Ti	1Cr18Ni12Mo2Ti	00Cr18Ni10	00Cr17Ni14Mo2		
3 衬里/阀座Lining/Seat	PTFE(F4)、PCTFE(F3)、FEP(F46)、PFA(可溶性F4)							
4 隔膜Diaphragm	FEP(F46)/CR(氯丁橡胶)、PFA(可溶性F4)/FPDM(乙丙橡胶)							
5 支架Yoke	WCB		CF8		CF8			
6 阀杆螺母Yoke nut	ZCuAl10Fe3		ZCuAl10Fe3		ZCuAl10Fe3			
7 紧固螺栓 Fastener bolt	35		1Cr17Ni2		1Cr18Ni9Ti			
8 螺母Nut	45		0Cr18Ni9		0Cr18Ni9			
9 手轮子Hand wheel	WCB		WCB		WCB			

主要外形和连接尺寸 Main External and Connection Dimension

单位Unit:mm

公称通径		标准值							参考值			
DN (mm)	NPS (inch)	L	D	D1	D2	f	b	Z-φd	D0	H	H1	WT(Kg)
PN0.6MPa												
15	1/2	125	80	55	40	2	12	4-φ12	100	105	110	3.5
20	3/4	135	90	65	50	2	14	4-φ12	100	115	125	4
25	1	145	100	75	60	2	14	4-φ12	120	120	135	5.5
32	1 1/4	160	120	90	70	2	16	4-φ14	120	125	150	8
40	1 1/2	180	130	100	80	3	16	4-φ14	140	135	175	11
50	2	210	140	110	90	3	16	4-φ14	140	155	195	14
65	2 1/2	250	160	130	110	3	16	4-φ14	200	170	200	23
80	3	300	185	150	125	3	18	4-φ18	200	200	255	29
100	4	350	205	170	145	3	18	4-φ18	280	270	325	46
125	5	400	235	200	175	3	20	8-φ18	320	335	405	70
150	6	460	260	225	200	3	20	8-φ18	320	370	450	95
200	8	570	315	280	255	3	22	8-φ18	400	480	600	170
250	10	680	370	335	310	3	24	12-φ18	500	545	620	270
300	12	790	435	395	362	4	24	12-φ23	500	585	680	320
PN1.6MPa												
15	1/2	130	95	65	45	2	14	4-φ14	120	110	115	4
20	3/4	150	105	75	55	2	16	4-φ14	120	120	130	5
25	1	160	115	85	65	2	16	4-φ14	140	125	140	6
32	1 1/4	180	135	100	78	2	18	4-φ18	140	130	155	9
40	1 1/2	200	145	110	85	3	18	4-φ18	160	140	180	12
50	2	230	160	125	100	3	20	4-φ18	160	160	200	15
65	2 1/2	290	180	145	120	3	20	4-φ18	200	175	205	24
80	3	310	195	160	135	3	22	8-φ18	200	205	260	30
100	4	350	215	180	155	3	24	8-φ18	280	275	330	48
125	5	400	245	210	185	3	26	8-φ18	320	340	410	75
150	6	480	280	240	210	3	28	8-φ23	320	375	460	105
200	8	600	335	295	265	3	30	12φ-23	400	485	605	182
250	10	730	405	355	320	3	32	12φ-25	500	550	625	295
300	12	850	460	410	375	4	34	12φ-25	500	590	685	345



GG641Fx型气动隔膜阀(往复式)

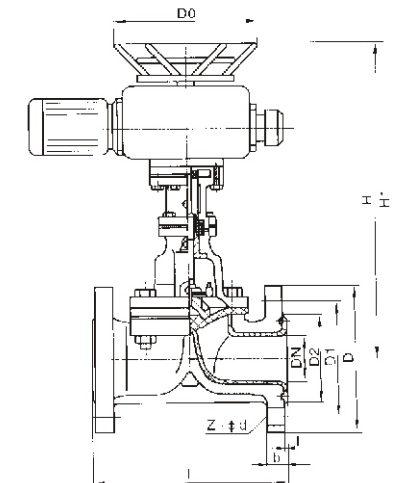
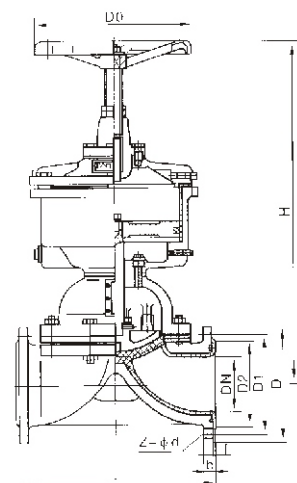

GG941Fx电动隔膜阀(堰式)

主要外形和连接尺寸 Main External and Connection Dimension

单位Unit:mm

公称通径		标准值							参考值			
DN (mm)	NPS (inch)	L	D	D1	D2	f	b	Z-φd	D0	H	H1	WT(Kg)
PN1.0MPa												
15	1/2	125	95	65	45	2	14	4-φ14	100	105	110	3.5
20	3/4	135	105	75	55	2	16	4-φ14	100	115	125	4
25	1	145	115	85	65	2	16	4-φ14	120	120	135	5.5
32	1 1/4	160	135	100	78	2	18	4-φ18	120	125	150	8
40	1 1/2	180	145	110	85	3	18	4-φ18	140	135	175	11
50	2	210	160	125	100	3	20	4-φ18	140	155	195	14
65	2 1/2	250	180	145	120	3	20	4-φ18	200	170	200	23
80	3	300	195	160	135	3	22	4-φ18	200	200	255	29
100	4	350	215	180	155	3	22	8-φ18	280	270	325	46
125	5	400	245	210	185	3	24	8-φ18	320	335	405	70
150	6	460	280	240	210	3	24	8-φ23	320	370	450	95
200	8	570	335	295	265	3	26	8-φ23	400	480	600	170
250	10	680	390	350	320	3	28	12-φ23	500	545	620	270
300	12	790	440	400	368	4	28	12-φ23	500	585	680	320
PN1.6MPa												
15	1/2	130	95	65	45	2	14	4-φ14	120	110	115	4
20	3/4	150	105	75	55	2	16	4-φ14	120	120	130	5
25	1	160	115	85	65	2	16	4-φ14	140	125	140	6
32	1 1/4	180	135	100	78	2	18	4-φ18	140	130	155	9
40	1 1/2	200	145	110	85	3	18	4-φ18	160	140	180	12
50	2	230	160	125	100	3	20	4-φ18	160	160	200	15
65	2 1/2	290	180	145	120	3	20	4-φ18	200	175	205	24
80	3	310	195	160	135	3	22	8-φ18	200	205	260	30
100	4	350	215	180	155	3	24	8-φ18	280	275	330	48
125	5	400	245	210	185	3	26	8-φ18	320	340	410	75
150	6	480	280	240	210	3	28	8-φ23	320	375	460	105
200	8	600	335	295	265	3	30	12φ-23	400	485	605	182
250	10	730	405	355	320	3	32	12φ-25	500	550	625	295
300	12	850	460	410	375	4	34	12φ-25	500	590	685	345

安全阀 Safety valve

Z41H, Z41Y, Z541H, Z541Y, Z941H, Z941Y

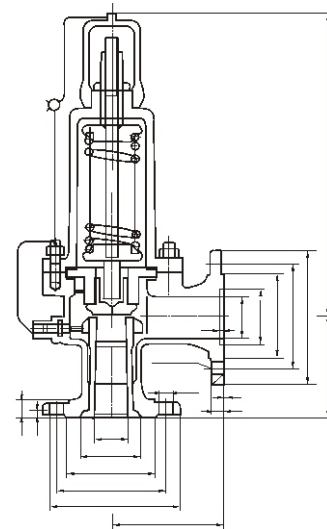

主要外形和连接尺寸 Main External and Connection Dimension

单位Unit:mm

产品规范 Product Specification	设计规范 Design Spec.	结构长度 Face to Face	连接法兰 Flange End	试验与检验 Test & Check	产品标识 Marking	供货规范 Supply
	GB/T 12243	GB/T 12221	JB/T 79	GB/T 12242	GB/T 12220	JB/T 7928

产品性能规范 Chief property and specification

公称压力PN Nominal Pressore	1.6	2.5	4.0	MPa
壳体强度试验PT Shell strength test	2.4	3.75	6.0	MPa
密封试验压力 Seal pressure test	0.9PK			MPa
开启压力PK Re-set Pressure	用户确定 Define by users			
适用介质 Suitable medium	C 水、油品、蒸汽 Water, oil, Steam	P 硝酸类 Nitri Acid	F 液化气 LPG	
适用温度 Applicable temperature	≤300°C	≤200°C	-400°C ~ +80°C	

主要零件材料 Material of major Parts

零件名称 Part name	材料 Material
阀体 Body	WCB
阀座 Seat	2Gr13
调节圈 Adjusting ring	ZG2Cr13
阀瓣 Disc	2Cr13
反冲盘 Disc holder	2Cr13
导向套 Disc guide	2Cr13
阀盖 Cover	WCB
阀杆 Stem	2Cr13
弹簧 Spring	50CrVA
调整螺杆 Adjusting bolt	35
阀座、阀瓣密封面 Seat/Disc sealing face	STL

微启式安全阀 Low-lift safety valve

Z41H, Z41Y, Z541H, Z541Y, Z941H, Z941Y, A41Y-160-320(P)

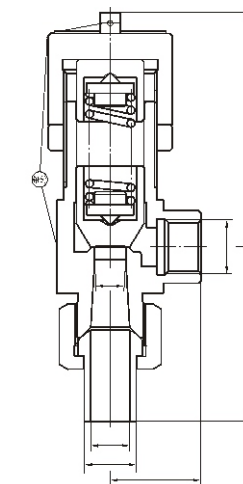
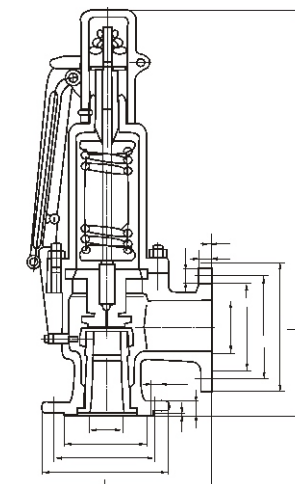
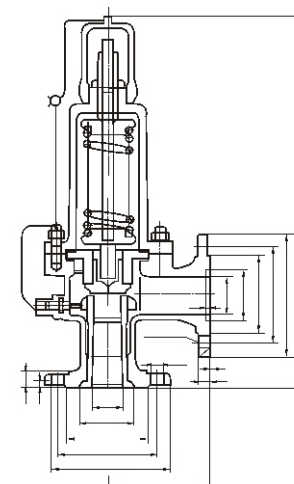

主要外形和连接尺寸 Main External and Connection Dimension

单位Unit:mm

公称通径 DN	L	L1	d0	DN' (Outlet)	WT(Kg)			
					1.6MPa	2.5MPa	4.0MPa	6.4MPa
25	100	85	20	25	7	10	11	20
32	115	100	25	32	15	15	15	25
40	120	110	32	40	20	20	20	31
50	135	120	40	50	25	25	25	35
65	140	130	50	65	40	47	54	60
80	160	135	65	80	52	65	70	75
100	170	160	80	100	70	75	78	86
125	190	190	100	125	95	101	110	122
150	205	195	125	150	132	140	151	170
200	240	230	150	200	168	182	194	210

公称通径 DN	L	L1	d0	DN' (Outlet)	WT(Kg)		
					1.6MPa	2.5MPa	4.0MPa
25	100	100	20	25	10	10	11
32	115	105	25	32	16	16	18
40	120	110	32	40	20	20	25
50	135	120	40	50	30	30	30
80	160	135	65	80	52	52	70
100	170	160	80	100	70	70	95

微启式管道安全阀 Pipeline safety valve

主要外形和连接尺寸 Main External and Connection Dimension

单位Unit:mm

公称通径 DN	PN1.6/2.5/4.0MPa					WT(Kg)
	L	L1	d0	D	G(Outlet)	
15	35	65	12	20	G ⁵ / ₈ "	4
20	42	76	16	25	G ³ / ₄ "	5
25	50	84	20	31	G1"	7
32	55	85	25	ZG1 ¹ / ₄ "	G1 ¹ / ₄ "	11
40	55	84	32	ZG1 ¹ / ₂ "	G1 ¹ / ₂ "	16
50	67	101	40	AG2"	G2"	23
65	76	120	50	ZG2 ¹ / ₂ "	G2 ¹ / ₂ "	27
80	83	135	65	ZG3"	G3"	40

全启式安全阀 Full-lift safety valve

PsZ41H, PsZ41Y, PsZ541H, PsZ541Y, PsZ941H, PsZ941Y, A42Y-160-320(P)

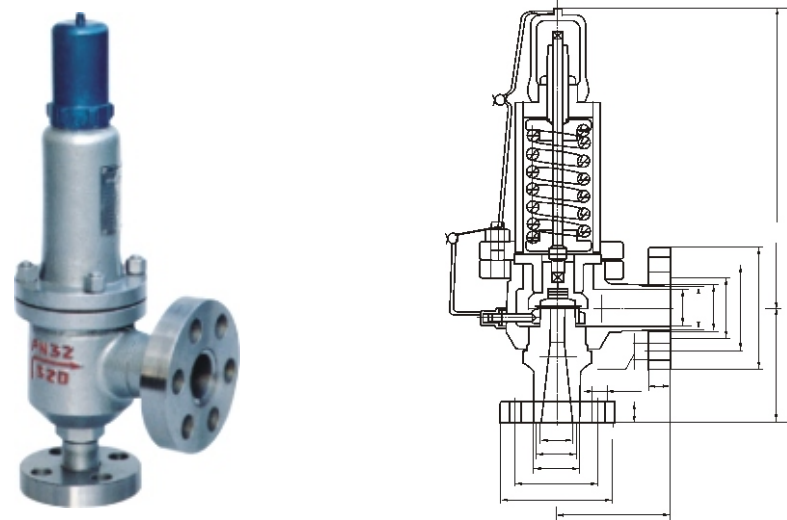

主要外形和连接尺寸 Main External and Connection Dimension

单位Unit:mm

公称通径 DN	10	15	20	25	32	40	50
		A42Y-160		A42Y-160P			
L	95	95	95	125	130	165	180
L1	100	100	100	125	135	165	180
d0	8	8	8	12	14	20	25
d	10	17	20	22	29	39	50
M	M27x2	M33x2	M36x2	M42x2	M48x2	M64x3	M80x3
D	95	105	110	115	135	165	200
D1	60	68	75	80	95	115	145
D2	22	27	30	37	41	58	74
Z-φd	3-φ18	3-φ18	3-φ18	4-φ18	4-φ22	6-φ26	6-φ29
b	20	20	20	22	25	32	40
DN'	29	29	29	39	50	65	80
D2'	37	37	37	47	59	73	94
M'	M42x2	M42x2	M42x2	M52x2	M64x3	M80x3	M100x3
D'	115	115	115	165	165	200	225
D1'	80	80	80	115	115	145	170
b'	22	22	22	28	32	35	45
Z-φd'	4-φ18	4-φ18	4-φ18	6-φ26	6-φ26	6-φ29	6-φ33
WT(Kg)	12	25	32	40	55	71	88
		A42Y-320		A42Y-320P			
L	95	95	95	125	130	165	180
L1	100	100	100	125	135	165	180
d0	8	8	8	12	14	20	25
d	10	15	20	22	29	39	50
M	M24x2	M24x2	M33x2	M36x2	M42x2	M52x2	M64x3
D	95	95	105	110	115	165	165
D1	60	60	68	75	80	115	115
D2	18	20	27	30	37	47	58
Z-φd	3-φ18	3-φ18	3-φ18	3-φ18	4-φ18	6-φ26	6-φ26
b	20	20	20	20	22	28	32
DN'	29	29	29	39	50	65	80
D2'	37	37	37	47	59	73	94
M'	M42x2	M42x2	M42x2	M52x2	M64x3	M80x3	M100x3
D'	115	115	115	165	165	200	225
D1'	80	80	80	115	115	145	170
b'	22	22	22	28	32	35	45
Z-φd'	4-φ18	4-φ18	4-φ18	6-φ26	6-φ26	6-φ29	6-φ33
WT(Kg)	12	25	32	40	55	71	88

带扳手全启式安全阀 Full-lift safety valve with level

A44Y-16~100(C/P)

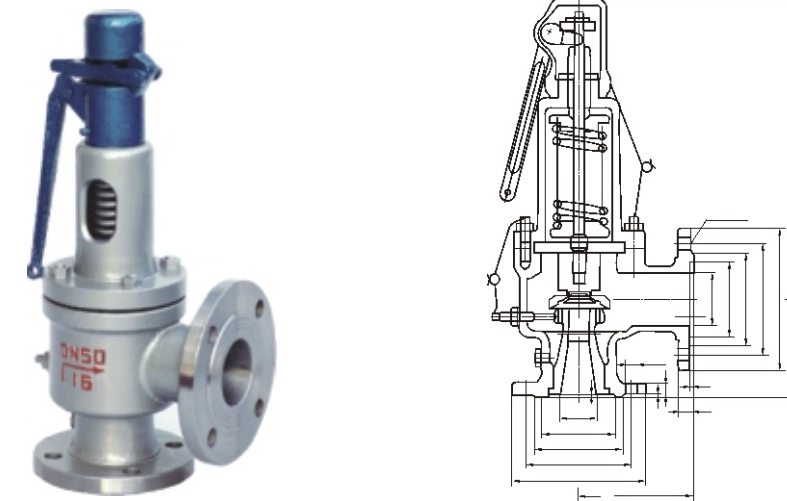

主要外形和连接尺寸 Main External and Connection Dimension

单位Unit:mm

公称通径 DN	L	L1	d0	DN' (Outlet)	重量 WT (Kg)		
					1.6MPa	4.0MPa	
		A44Y-16C	A44Y-25	A44Y-40	A44Y-16P	A44Y-25P	A44Y-40P
25	110	95	15	32	15	20	
32	115	100	20	40	21	22	
40	120	110	25	50	25	26	
50	135	120	32	65	30	32	
65	160	140	40	80	42	49	
80	170	135	50	100	65	70	
100	195	175	65	125	80	95	
150	255	230	100	175	135	155	
200	300	260	125	250	175	205	

主要外形和连接尺寸 Main External and Connection Dimension

单位Unit:mm

公称通径 DN	L	L1	d0	DN' (Outlet)	重量 WT (Kg)	
					6.4MPa	10.0MPa
		A44Y-64	A44Y-100	A44Y-64P	A44Y-100P	
25	110	105	15	32	22	24
32	130	110	20	40	28	32
40	130	120	25	50	36	44
50	155	130	32	65	70	78
80	175	160	50	100	90	105
100	195	195	65	125	115	133
150	285	260	100	200	180	196

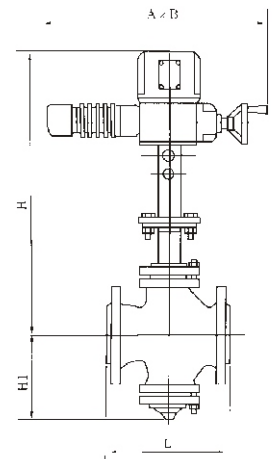

(ZAZP 常温型)
(ZAZP ordinary temperature type)

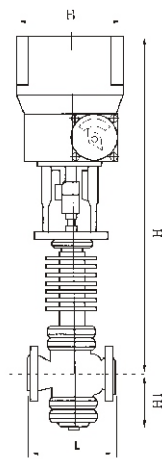

(ZAZP 散热型)
(ZAZP heat radiation type)

主要外形和连接尺寸 Main External and Connection Dimension

单位 Unit:mm

公称 口径 DN	L			ZAZP型 Type			ZAZP型 Type			A (长) Long	B (宽) Width	电动执行 机构型号 Electric actuator framework type	出轴推力 Mpa (kgf/cm ²) Output thrust	行程 h(mm) Journey	额定流量系数C Rating flux coefficient			
	PN1.6 (Mpa)	PN4.0 (Mpa)	PN6.4 (Mpa)	H		H1	H		H1						单座 One- seater	双座 Two- seater		
				常温型 Normal temperature	散热型 Heat -scattering type		常温型 Normal temperature	散热型 Heat -scattering type										
20	180	185	190	495	655	95	-	-	-	490	KAZ-25 KDZ-310	2.5、40 (25.400)	10	1.2-5	-			
25	185	190	205	767	928	112	787	937	117					KAZ-310	40 (400)	16	8	10
32	200	210	220	793	940	118	793	943	120								20	25
40	220	230	240	812	963	129	832	982	139									
50	250	255	265	842	993	144	842	992	144					520	KDZ-410	64 (640)	40	50
65	275	285	295	967	1127	178	987	1147	188	80	100							
80	305	310	325	990	1142	191	1017	1177	208	120	160							
100	350	355	370	999	1151	195	1041	1207	220	200	250							
125	410	425	440	1092	1307	245	1142	1357	270	280	400							
150	450	460	475	1112	1327	255	1162	1377	280	450	630							
200	550	560	570	1187	1402	290	1244	1459	320	630	KDZ-510	160 (1600)	100	700	1000			
250	670	740	750	-	-	-	1472	1599	440					1000	1600			
300	770	805	820	-	-	-	1530	1747	502									

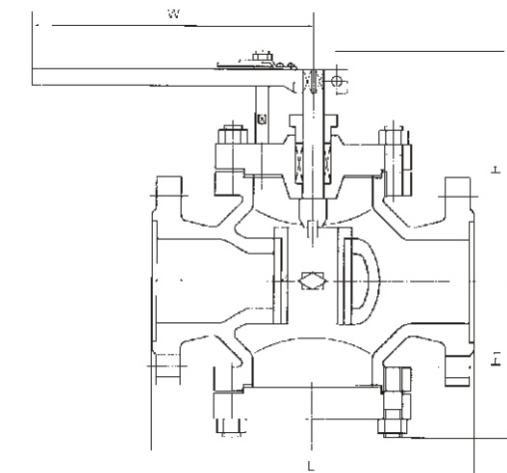

主要外形和连接尺寸 Main External and Connection Dimension

单位 Unit:mm

公称 口径 DN	PN1.6/2.5MPa				WT (Kg)	PN4.0/6.4/10.0MPa				WT (Kg)
	L	H	H1	W		L	H	H1	W	
T40H-16 T40H-16C T40H-25 T40H-40 T40H-64 T40H-100										
20	160	180	90	140	4	180	185	100	150	4
25	180	200	100	150	7	200	210	110	160	8
32	200	205	100	180	12	220	220	110	190	14
40	220	210	120	200	38	240	225	135	210	40
50	250	230	120	230	55	270	250	135	245	60
65	280	240	130	240	91	300	250	140	270	95
80	310	250	150	270	92	330	260	160	300	98
100	350	280	150	300	121	380	300	180	330	130
125	400	290	190	350	121	450	310	200	380	130
150	450	300	205	380	167	500	320	220	420	175
200	550	325	270	440	267	550	340	230	500	280
250	650	330	270	400	415	650	360	300	560	420
300	800	450	335	650	580	800	480	370	720	600

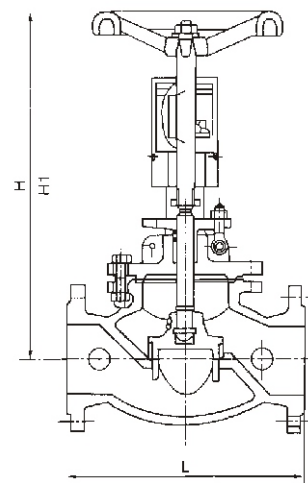

手动自锁平衡调节阀 (KPF型)
manual self-locking balanced control valve (KPF type)

概述:

本公司生产的KPF型平衡调节阀是一种具有特殊功能的阀门，它除具有调节阀功能外，还能实现流量定量，可以有效地解决供热（空调）系统中存在的室温冷热不均问题。由于该阀上设有开启度指示，开度锁定装置及用于流量测定的测压小阀，所以只要在各支路及用户入口处装上适当规格的平衡阀，并用专用智能仪表进行一次调试后锁定，将系统的总水量控制在合理范围内，就能克服了“大流量、小温差”的不合理现象。该产品是供热系统中理想产品。

Summary

The company has produced KPF model of balance adjustable valve Besides adjustable function, it can realize ration of capacity,efficiently solve the problem of unequally cold and hot room temperature in heating system(air-condition).due to this valve has indicator of open degree,thereby,as long as suitable is will to debug once and lock the setting,the control system total capacity will be in a reasonable range to overcome the unreasonable phenomenon of large acpacity "and"small temperature differential".This product is ideal in heating system .

采用标准 Adopt standard

设计标准 Design standard	GB12235-89
结构长度 Face to face	GB12221-89
配管法兰 Tubing flange	JB/T79-94、GB4216
试验与检验 Test and check up	GB/T13927-92、JB/T9092-99
传动方式 Drive mode	手动、齿轮动、电动 Manual, conical gear actuator, electric

主要性能参数 Main performance paramteter

公称压力 Nominal pressure	1.0	1.6	2.5	Mpa
壳体试验 Shell test	1.5	2.4	3.75	
密封试验 Seal test	1.1	1.76	2.75	
适用介质 Suitable medium	水、蒸气 Water, steam			
工作温度 Working temperature	-29 ~ +350°C			

主要外形和连接尺寸 Main External and Connection Dimension

单位 Unit:mm

型号 Model	KPF-16																		
公称压力 PN(MPa)	1.6																		
公称口径 DN(MPa)	15	20	25	32	40	50	65	80	100	125	150	200	250	300	350	400	500	600	
尺寸 (mm)	L	130	150	160	180	200	230	290	310	350	400	480	495	622	698	787	914	978	1295
	H	150	160	182	192	250	264	380	413	446	540	623	687	782	914	968	1037	1440	1790
	H1	160	170	197	207	270	284	410	448	506	595	688	762	867	1009	1073	1152	1440	1790
	D0	80	180	80	90	100	120	200	200	240	240	360	400	500	500	680	680		

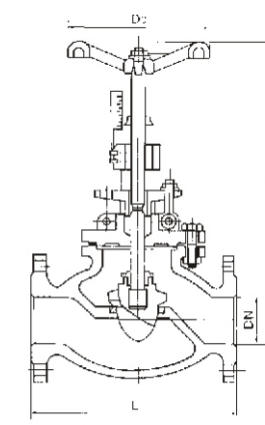
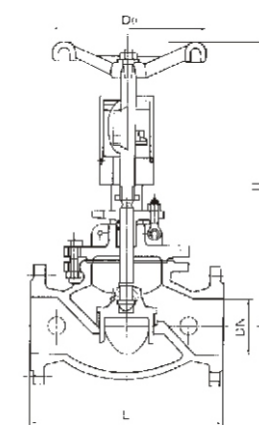
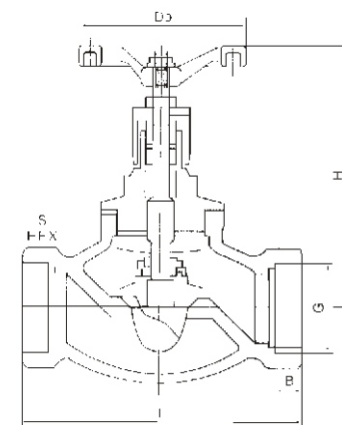

自锁型 Self-Lock

主要外形和连接尺寸 Main External and Connection Dimension

单位 Unit:mm

公称口径 DN	主要外形尺寸和连接尺寸 (mm) Main external and connecting dimensions							WT(Kg)
	L	G	B	S	H	H1	D0	
TJ10H-10 TJ10H-16 TJ10H-16C TJ10H-25								
15	90	1/2"	16	32	160	170	80	0.9
20	100	3/4"	18	36	160	172	120	1.1
25	120	1"	20	46	182	195	160	1.8
32	140	1 1/4"	22	55	192	210	180	2.6
40	170	1 1/2"	24	60	250	273	200	3.8
50	200	2"	26	75	264	290	230	5.7

主要外形和连接尺寸 Main External and Connection Dimension

单位 Unit:mm

公称口径 DN	主要外形尺寸和连接尺寸 (mm) Main external and connecting dimensions				WT(Kg)
	L	H	H1	D0	
TJ40H-10 TJ40H-16 TJ40H-16C TJ40H-25 TJS40H-10 TJS40H-16 TJS40H-16C TJS40H-25					
15	130	160	172	80	2.5
20	150	160	172	120	3.5
25	160	182	195	160	4.8
32	180	192	210	180	7
40	200	250	273	200	9.5
50	230	264	290	230	13.5
65	290	380	426	230	29
80	310	413	468	270	35
100	350	466	530	320	56
125	400	540	613	340	79
150	480	623	698	400	117
200	600	687	777	500	185
250	730	915	1030	560	327
300	850	940	1080	680	422
350	980	968	1128	680	610
400	991	990	1175	720	750
450	1092	1100	1300	800	-
500	1194	1130	1360	800	-

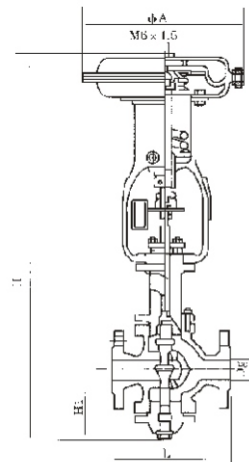

(ZAZP 常温型)
(ZAZP ordinary temperature type)

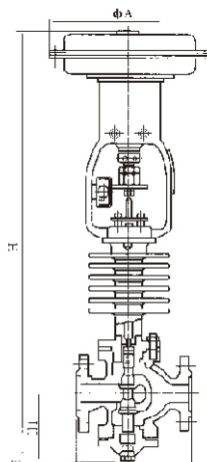

(ZMBN 散热型)
(ZMBN heat radiation type)

主要外形和连接尺寸 Main External and Connection Dimension

单位 Unit:mm

公称 口径 DN	L		ZM2P型 Type		ZM2P型 Type			φA	输出压力(kgf/cm ²) Output pressure				额定流量系数C Rating flux coefficient	
			PN1.6 (Mpa)	PN6.4 (Mpa)	H		H1		H		单座 One-seater	双座 Two-seater		
	常温型 Normal temperature	散热型Heat -scattering type			常温型 Normal temperature	散热型Heat -scattering type								
									允许压盖 Allowable gland		允许压盖 Allowable gland			
20	180	190	654	799	93	-	-	-	13	27	-	-	1.2-5	-
25	185	205	669	725	110	679	785	117	8	16	54	64	8	10
32	200	220	680	786	120	684	790	120	5	11	44	64	12	16
40	220	240	754	854	130	774	874	138	5	10	46	64	20	25
50	250	265	785	885	145	785	885	144	3	6	38	64	32	40
65	275	295	991	1138	180	1011	1158	188	3	6	47	64	50	63
80	305	325	1008	1162	190	1042	1196	208	2	4	36	64	80	100
100	350	370	1015	1169	195	1065	1219	220	1.2	2.4	28	56	120	160
125	410	440	1268	1461	240	1318	1501	267	1.2	2.4	37.5	64	200	250
150	450	475	1286	1469	250	1340	1523	278	0.8	1.6	27	54	280	400
200	550	570	1363	1546	290	1423	1660	320	0.8	1	21.5	43	450	630

特点: 单座调节阀: 具有易密封, 泄漏量少的特点, 但不平衡力较大, 故工作压差不宜过高。
双座调节阀: 具有额定流量系数大, 不平衡力小等优点, 因而被广泛应用。

Characteristic: Single-seat adjustable valve: seal easily, little leakage, big imbalance force, thereby working gland can't be very high.
Double seats adjustable valve: with advantages of large rated capacity coefficient, small imbalance, force, thereby it is used widely.

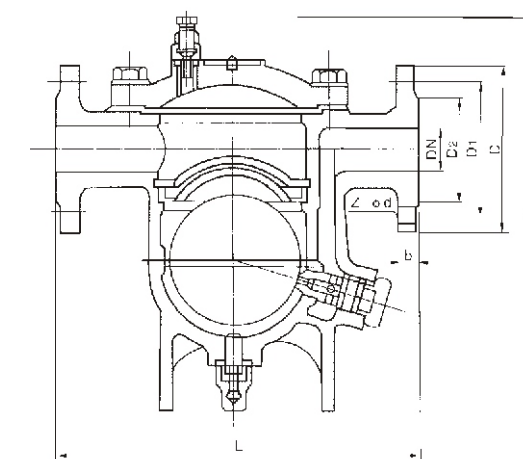

产品执行标准 Production enforce standard

产品规范 Product Specification	设计规范 Design Spec	结构长度 Face to Face	连接法兰 Flange End	试验与检验 Test & Check	产品标识 Marking	供货规范 Supply Spec
	JB/T 9093	GB/T 12250	GB/T 9113	GJB/T 12251	GB/T 12249	JB/T 7928

产品性能规范 Chief property and specification

型号 Type	公称压力 Nominal pressure PN(MPa)	壳体试验压力 Shell test pressure Ps(MPa)	最高工作压力 Max works pressure PMO(MPa)	最高工作温度 Max works temperature TMO(°C)	最高允许温度 Max vouchsatement temperature TMO(°C)	漏气率 Leakage rate(%)	最高背压率 Max stress rate(%)	适用介质 Applicable medium
CS41H-16 S41H-16 CS41H-16C S41H-16C	1.6	2.4	1.6	203	220 425	<0.5 <0.5	>80 >80	蒸气、凝结水 蒸气、凝结水
CS41H-40 S41H-40	4.0	6.0	4.0	250	425	<0.5	>80	蒸气、凝结水

主要零件材料 Material for main parts

零件名称 Name of parts	阀体、阀盖 Body、bonnet	阀体、球、过滤网 Seat, Ball, percolator
CS41H-16、S41H-16	灰铸钢 Gray cast iron	不锈钢 Stainless steel
CS41H-16C、S41H-16C CS41H-16、S41H-16	碳素铸钢 Carbon casting steel	不锈钢 Stainless steel

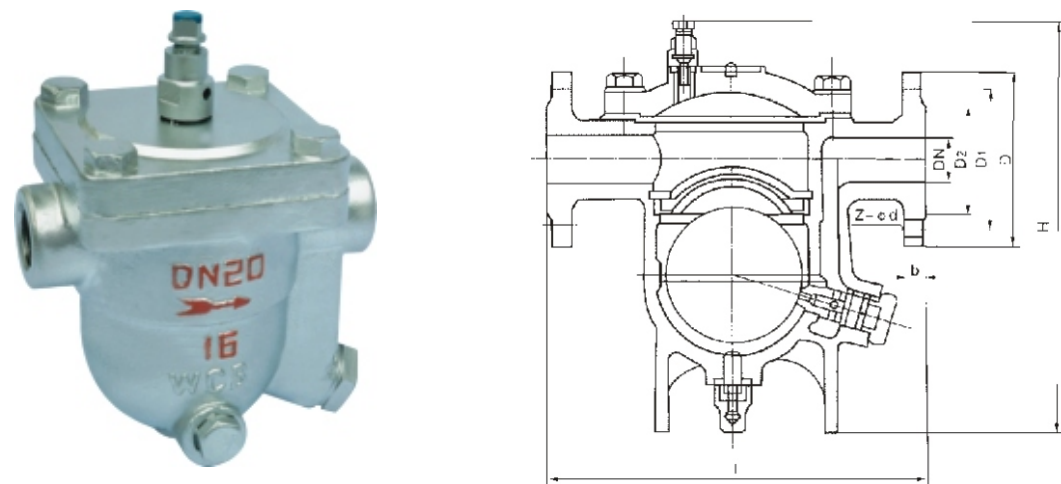

主要外形和连接尺寸 Main External and Connection Dimension

单位 Unit:mm

公称通径 DN	主要外形尺寸和连接尺寸 (mm) Main external and connecting dimensions				WT (Kg)
	L	G	H	H ₁	
CS11H-16C-C CS11H-25-C CS11H-40-C CS11H-16C-D CS11H-25-D CS11H-40-D					
15	170	1/2"	176	120	2.6
20	170	3/4"	176	120	2.8
25	170	1"	176	120	3.0
25	230	1"	215	158	5.2
32	230	1 1/4"	217	162	5.4
40	230	1 1/2"	221	166	5.6

主要外形和连接尺寸 Main External and Connection Dimension

单位 Unit:mm

公称通径 DN	主要外形尺寸和连接尺寸 (mm) Main external and connecting dimensions							WT (Kg)
	L	D	D ₁	D ₂	b	Z-φd	H	
CS41H-16C-C CS41H-25-C CS41H-40-C CS41H-16C-D CS41H-25-D CS41H-40-D CS41H-16C-E CS41H-25-E CS41H-40-E CS41H-16C-F CS41H-25-F CS41H-40-F								
15	195	95	65	45	14	4-φ14	195	10.5
20	195	105	75	55	14	4-φ14	200	11.2
25	215	115	85	65	14	4-φ14	225	11.5
25	270	115	85	65	14	4-φ14	245	10.5
32	270	135	100	78	16	4-φ18	250	11.2
40	280	145	110	85	16	4-φ18	290	11.5
40	280	145	110	85	16	4-φ18	290	10.5
50	410	160	125	100	16	4-φ18	380	11.2
65	410	180	145	120	18	4-φ18	380	11.5
50	430	165	125	102	20	4-φ18	467	72
65	430	185	145	122	20	4-φ18	475	74
80	460	200	160	132	22	8-φ18	492	77

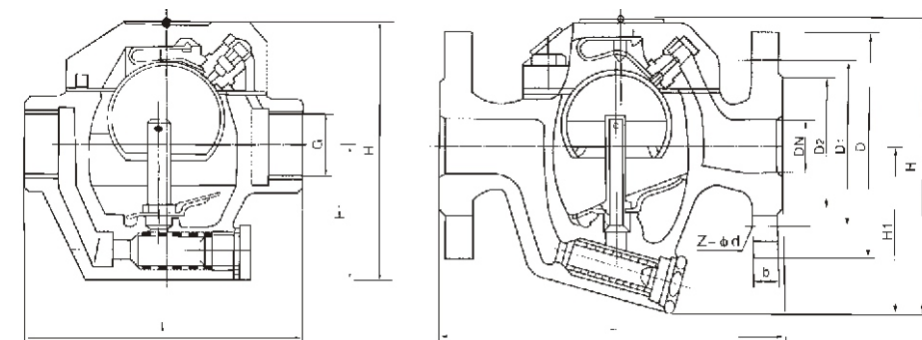

主要外形和连接尺寸 Main External and Connection Dimension

单位 Unit:mm

公称通径 DN	主要外形尺寸和连接尺寸 (mm) Main external and connecting dimensions				WT (Kg)
	L	G	H	H ₁	
CS15H-16C CS15H-25 CS15H-40					
15	155	1/2"	142	80	5.4
20	155	3/4"	142	80	5.5
25	155	1"	142	80	5.6
32	180	1"	200	105	5.7
40	180	1"	200	105	6
50	180	2"	200	105	6.5

主要外形和连接尺寸 Main External and Connection Dimension

单位 Unit:mm

公称通径 DN	主要外形尺寸和连接尺寸 (mm) Main external and connecting dimensions								WT (Kg)	
	L	D	D ₁	D ₂	b	Z-φd	H	H ₁		
CS45H-16C CS45H-25 CS45H-40										
15	210	95	65	45	14	4-φ14	142	65	10	
20	210	105	75	55	14	4-φ14	142	65	13	
25	230	115	85	65	14	4-φ14	142	65	16	
32	270	135	100	78	16	4-φ18	200	105	18	
40	270	145	110	85	16	4-φ18	200	105	20	
50	270	160	125	100	16	4-φ18	200	105	23	

圆盘式疏水阀 Disc Trap Valve

CS19/49H-16-40C/E/D/F

双金属片式疏水阀 Bimetal elements steam trap

CS17/47H-16C-40

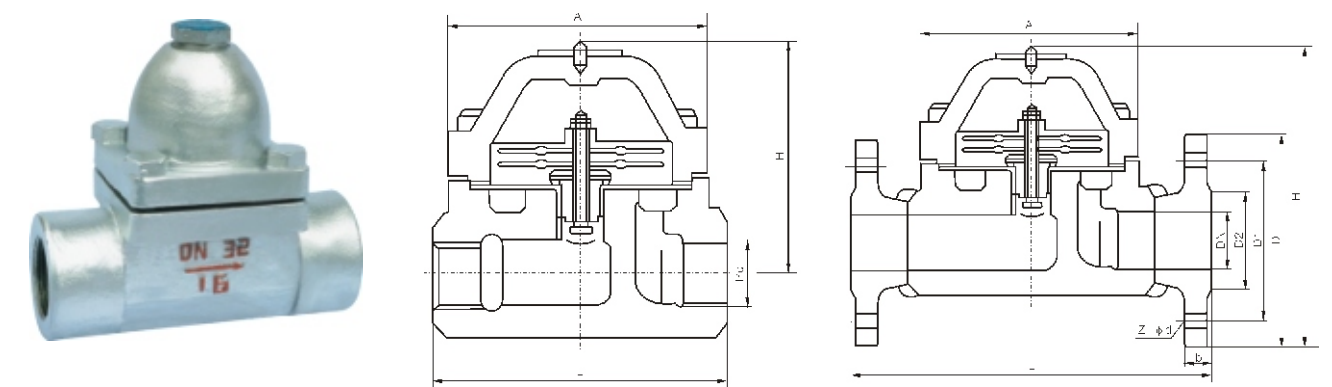
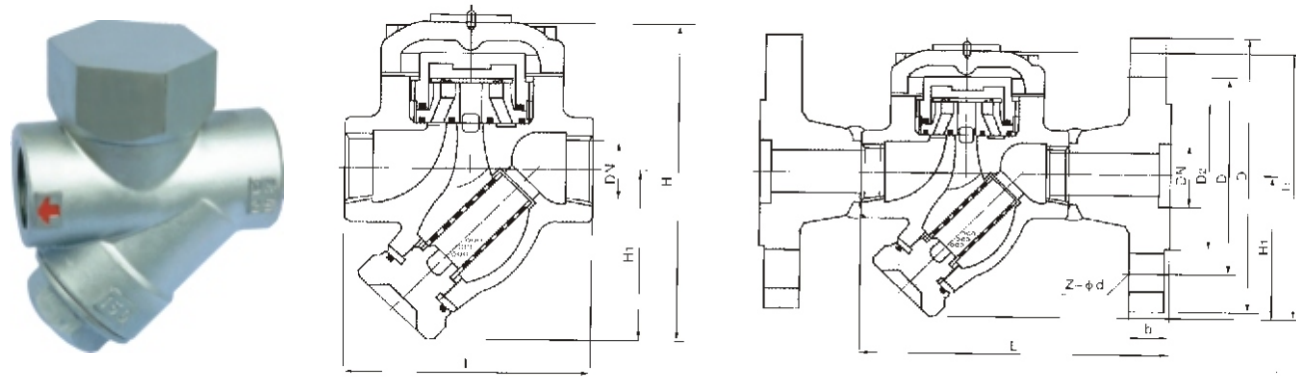

主要外形和连接尺寸 Main External and Connection Dimension

单位 Unit:mm

	主要外形尺寸和连接尺寸 (mm) Main external and connecting dimensions				WT (Kg)
	L	Rc	H	H ₁	
	CS19H-16C CS19H-25 CS19H-40				
15	85	1/2"	105	45	1.5
20	85	3/4"	105	45	1.8
25	95	1"	110	50	2.2
32	110	#	115	50	3.1
40	120	#	125	55	7.2
50	130	2"	135	55	8.5

主要外形和连接尺寸 Main External and Connection Dimension

单位 Unit:mm

公称通径 DN	主要外形尺寸和连接尺寸 (mm) Main external and connecting dimensions							WT (Kg)	
	L	D	D ₁	D ₂	b	Z-φd	H		H ₁
	CS49H-16C CS49H-25 CS49H-40								
15	150	95	65	45	14	4-φ14	105	53	3
20	150	105	75	55	14	4-φ14	105	53	3.2
25	160	115	85	65	14	4-φ14	110	58	3.5
32	230	135	100	78	16	4-φ18	110	58	5.2
40	230	150	110	85	16	4-φ18	125	65	8.3
50	230	165	125	100	16	4-φ18	135	70	10.3

主要外形和连接尺寸 Main External and Connection Dimension

单位 Unit: mm

产品型号 Type	CS17H-16C-25-40				WT (Kg)
	L	Rc	A	H	
公称通径 DN	PN1.6/2.5/4.0MPa				
15	90	1/2"	80	90	2.0
20	100	3/4"	80	90	2.2
25	100	1"	160	87	3.0

主要外形和连接尺寸 Main External and Connection Dimension

单位 Unit: mm

产品型号 Type	CS47H-16C-25-40							WT (Kg)
	L	D	D ₁	D ₂	b	Z-φd	H	
公称通径 DN	PN1.6/2.5/4.0MPa							
15	150	95	65	45	14	4-φ14	95	4
20	150	105	75	55	14	4-φ14	95	4.5
25	160	115	85	65	14	4-φ14	95	6
32	210	135	100	78	16	4-φ18	120	8
40	210	145	110	85	16	4-φ18	120	9
50	210	160	125	100	16	4-φ18	150	13

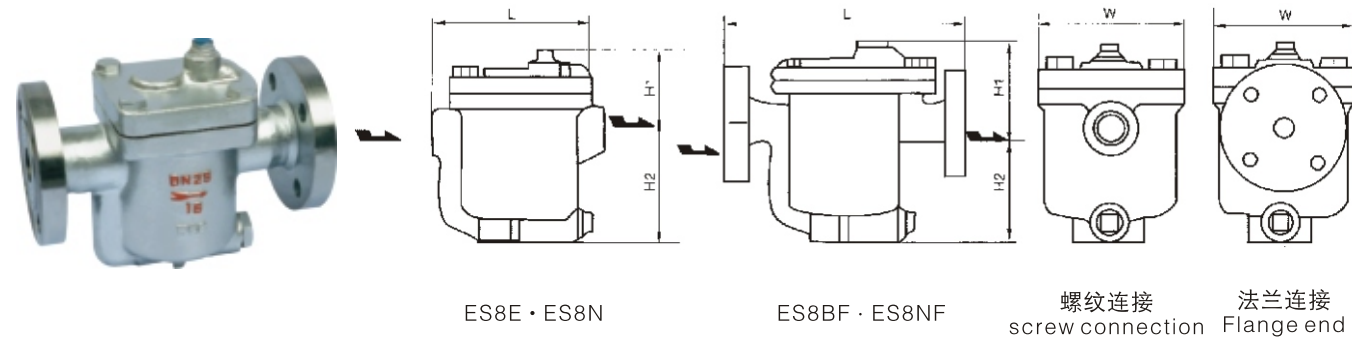

主要外形和连接尺寸 Main External and Connection Dimension

产品型号 Product type	公称通径 DN	连接方式 Connection type	使用压力范围(Mpa) Using pressure range(Mpa)	最高允许温度℃ Maximum allowable temperature℃	阀体材质 Body material	外形尺寸 (mm) Extend dimension(mm)			
						L	H1	H2	W
ES5 (CS15H-3 · 7 · 11 · 16)	15 20 25	内螺纹 ZG1/2"~1" inside screw ZG1/2"~1"	0.01~0.3 · 0.7 · 1.1 · 1.6	350	ZG1Cr1BNI9Ti	138	72	94	103
ESU5 (CS15H-3 · 7 · 11 · 16P)	15 20 25	内螺纹 ZG1/2"~1" inside screw ZG1/2"~1"	0.01~0.3 · 0.7 · 1.1 · 1.6 · 2.1	350	ZG1Cr1BNI9Ti	138	72	94	103
ESU5F (CS45H-3 · 7 · 11 · 16P)	15 20 25	法兰End	0.01~0.3 · 0.7 · 1.1 · 1.6 · 2.1	350	WCB	210			
ES8B (CS15H-5 · 8 · 16)	15 20 25	内螺纹 ZG1/2"~1" inside screw ZG1/2"~1"	0.01~0.5 · 0.8 · 1.6	220	WCB	138	72	94	103
ES8N (CS15H-5 · 8 · 16)	15 20 25	内螺纹 ZG1/2"~1" inside screw ZG1/2"~1"	0.01 · 0.5 · 0.8 · 1.6	220	WCB	138	72	94	103
ES8BF (CS45H-5 · 8 · 16)	15 20 25	法兰End	0.01~0.5 · 0.8 · 1.6	220	WCB	210	72	94	103
ES8NF (CS45H-5 · 8 · 16)	15 20 25	法兰End	0.01~0.5 · 0.8 · 1.6	220	WCB	210	72	94	103
ES10 (CS15H-8 · 12 · 16)	20~40	法兰End	0.01~0.8 · 1.2 · 1.6	220	WCB	200	93	132	142
ES10F (CS45H-8 · 12 · 16)	15~25 32~50	法兰End	0.01~0.8 · 1.2 · 1.6	220	WCB	270	93	132	142
ES12N (CS45H-16)	15~25 32~50	法兰End	0.01~1.6	200	WCB	280	93	132	142

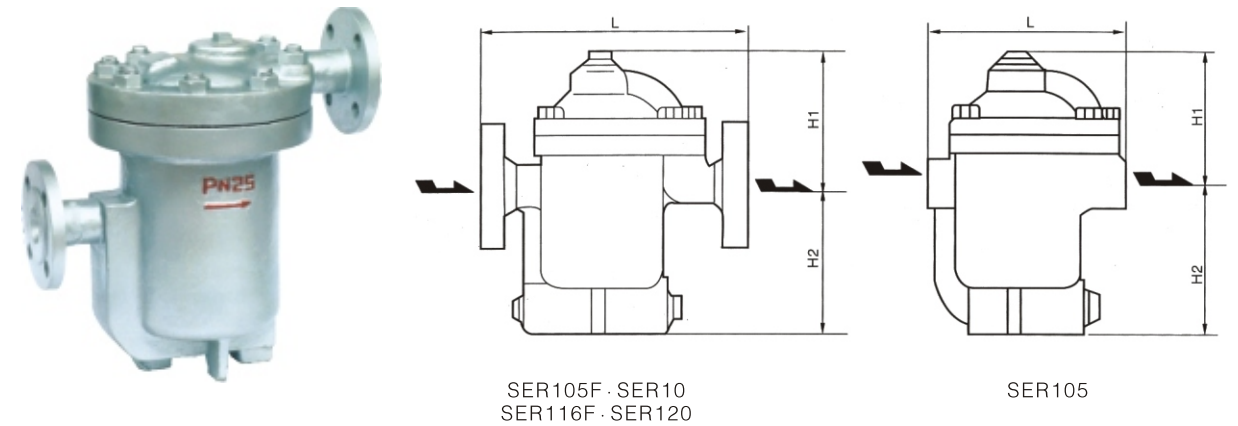

主要外形和连接尺寸 Main External and Connection Dimension

产品型号 Product type	公称通径 DN	连接方式 Connection type	使用压力范围(Mpa) Using pressure range(Mpa)	最高允许温度℃ Maximum allowable temperature℃	阀体材质 Body material	主要零件材质 Material for main parts	外形尺寸 (mm) Extend dimension(mm)			
							L	H1	H2	W
SER105 (CS15H-3.7)	20~40	内螺纹 ZG1/2"~11/2" inside screw ZG1/2"~11/2"	0.01~0.3~0.7	202	WCB	SUS (3Cr13)	200	155	134	-
SER105F (CS45H-3.7)	15~25 32~50	法兰End	0.01~0.3~0.7	220	WCB	SUS (3Cr13)	270	155	134	-
SER110 (CS45H-5.12)	15~25 32~50	法兰End	0.01~0.5~1.2	220	WCB	SUS (3Cr13)	310	220 180	131 167	-
SER116 (CS45H-7.16)	15~25 32~50	法兰End	0.01~0.7~1.6	220	WCB	SUS (3Cr13)	310	220 180	131 167	-
SER120 (CS45H-8.16)	40~65	法兰End	0.05~0.8~1.6	220	WCB	SUS (3Cr13)	420	220	214	-
SER25 (CS45H-25-45-65)	15~50	法兰End	0.05~2.5~4.5~6.5	425 (470)	WCB	SUS (3Cr13)	380	210	180	345
SER25w (CS65H-21c-45-65)	15~50	承插焊 Socket welding	0.05~2.5~4.5~6.5	425 (470)	WCB	SUS (3Cr13)	380	210	180	345

Y型过滤器 Y-Type Strainer

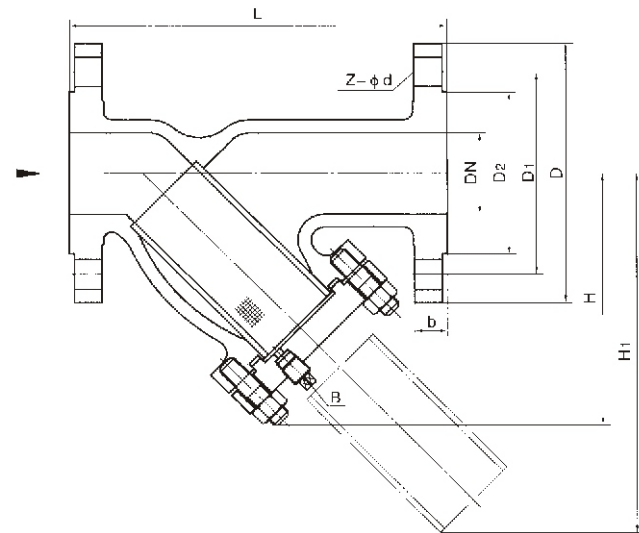

产品执行标准 Production enforce standard

产品规范 Product Specification	设计规范 Design Spec	结构长度 Face to Face	连接法兰 Flange End	试验与检验 Test & Check	产品标识 Marking	供货规范 Supply Spec
	HG/T21637	GB/T12221	JB/T79	JB/T9092	GB/T12220	JB/T 7928

产品性能规范 Chief property and specification

型号	连接方式	公称压力 PN(MPa)	耐压试验压力 (Mpa)	工作压力 (Mpa)	壳体材料	过滤网材料	网眼总面积
SY41P-10	法兰	1.0	1.1	1.0	灰铸铁	不锈钢	3~4DN
SY41P-16	法兰	1.6	1.76	1.6	球墨铸铁		
SY41P-25	法兰	2.5	2.75	2.5	碳钢		

主要零部件材料 Main part Material

零件名称	零部件材料 Part Material						Part Name
阀体/阀盖	25	WCB	CF8	CF8M	CF3	CF3M	Body/Bonnet
网架	25	35	1Cr18Ni9Ti	1Cr18Ni12Mo2Ti	00Cr18Ni10	00Cr17Ni14Mo2	Disc/Stem
滤网	1Cr18Ni9Ti		1Cr18Ni9Ti		00Cr18Ni10		Strainer
垫片	18-8/柔性石墨/18-8Flexible Graphite						Gasket
螺栓	35		1Cr17Ni2		1Cr18Ni9Ti		Bolt
适用温度	-29~+425°C		-40~+200°C		-40~+200°C		Suitable Temp
适用介质	水、油品、蒸气 Water, Oil, Steam		硝酸类 Nitric Acid		醋酸类 Acetic Acid		Suitable Medium

Y型过滤器 Y-type Strainer

SY14C/SY14S-H1~H300(A150)

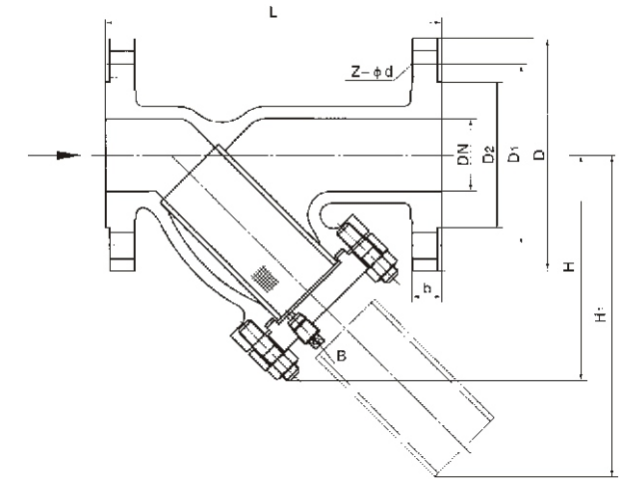

主要外形和连接尺寸 Main External and Connection Dimension

单位 Unit:mm

公称通径 DN	L	H	H ₁	B	有效过滤面积 Strainer Area (m ²)	WT(Kg)							
						SY14C			SY14S				
						PN1.0	PN2.5	PN4.0	PN1.0	PN2.5	PN4.0		
						SY14C-H10	SY14C-H16	SY14C-H25	SY14C-H40	SY14S-H10	SY14S-H16	SY14S-H25	SY14S-H40
15	110	87	120	ZG3/8"	0.00185	2.62	2.74	2.81	2.80	2.85	2.85		
20	130	105	148	ZG1/2"	0.00281	3.00	3.06	3.06	3.05	3.11	3.11		
25	150	114	176	ZG1/2"	0.00343	3.70	3.78	3.98	3.80	3.84	3.84		
32	160	124	193	ZG1/2"	0.00486	5.35	5.46	5.46	5.43	5.54	5.54		
40	200	156	237	ZG1/2"	0.00767	6.54	6.60	7.01	6.62	6.72	6.72		
50	220	181	270	ZG1/2"	0.01160	9.21	9.46	9.97	10.9	11.1	11.1		
65	290	250	369	ZG3/4"	0.02111	20.2	21.6	22.7	22.4	23.9	24.1		
80	310	280	429	ZG3/4"	0.03029	23.4	25.1	27.4	26.6	27.7	28.5		
100	350	320	488	ZG3/4"	0.04033	31.2	34.2	38.3	34.6	37.1	38.8		
125	400	374	547	ZG3/4"	0.05589	44.1	49.1	56.9	50.5	54.6	57.8		
150	480	430	622	ZG3/4"	0.07709	54.5	61.3	72.0	63.9	70.7	74.2		
200	550	515	741	ZG3/4"	0.11967	81.0	93.3	127.7	85.3	97.0	120.5		

主要外形和连接尺寸 Main External and Connection Dimension

单位 Unit:mm

NPS	DN	L	H	H ₁	B	有效过滤面积 Strainer Area (m ²)	WT(Kg)			
							SY14C		SY14S	
							150Lb	300Lb	150Lb	300Lb
							SY14C-A150	SY14S-A150	SY14C-H300	SY14S-H300
1/2	15	110	87	120	NTP1/8"	0.00185	1.96	2.47	2.10	2.51
3/4	20	130	105	148	NTP1/2"	0.00281	2.25	3.35	2.29	3.40
1	25	150	114	176	NTP1/2"	0.00343	3.05	4.19	3.10	4.25
1 1/4	32	160	124	193	NTP1/2"	0.00486	4.14	5.85	4.21	5.64
1 1/2	40	200	156	237	NTP1/2"	0.00767	6.09	8.49	6.20	8.63
2	50	220	181	270	NTP1/2"	0.01160	8.57	11.0	9.86	11.2
2 1/2	65	290	259	369	NPT3/4"	0.02111	22.7	27.7	23.6	29.0
3	80	310	293	429	NPT3/4"	0.03029	25.2	37.6	27.8	38.2
4	100	350	324	488	NPT3/4"	0.04033	33.7	58.0	36.7	57.2
5	125	400	390	547	NPT3/4"	0.05589	48.1	76.4	52.1	76.6
6	150	480	448	622	NPT3/4"	0.07709	59.7	112.1	66.8	104.4
8	200	550	535	741	NPT3/4"	0.11967	87.3	183.2	91.2	175.6

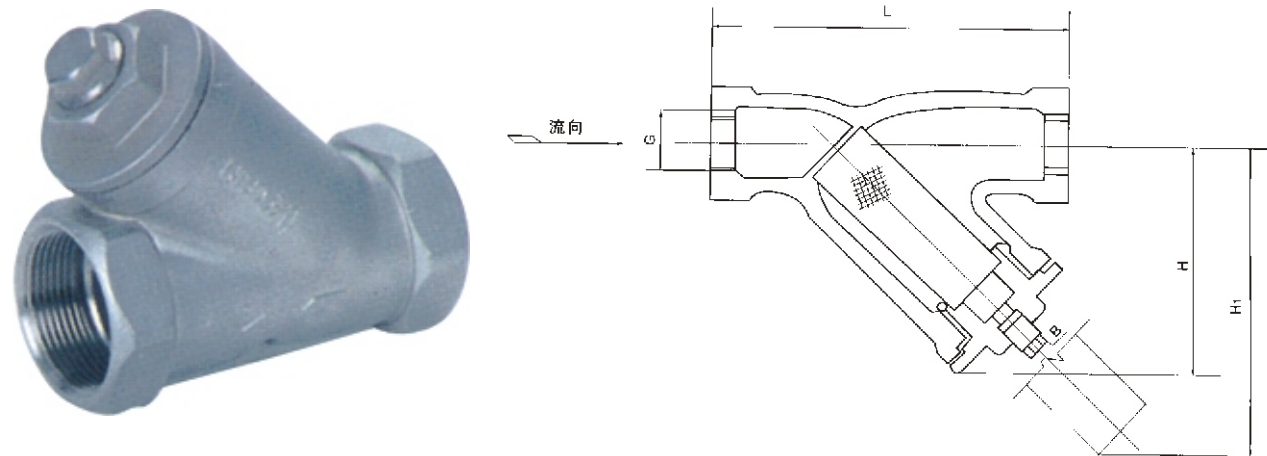

主要外形和连接尺寸 Main External and Connection Dimension

单位 Unit:mm

公称通径 DN	L	G	H	H1	B	有效过滤面积 Strainer Area (m ²)	WT (Kg)
SY11C-H10 SY11C-H16 SY11C-H25							
15	100	1/2"	74	99	ZG3/8"	0.00185	0.78
20	110	3/4"	88	127	ZG1/2"	0.00281	1.10
25	130	1"	103	150	ZG1/2"	0.00343	1.43
32	160	1 1/4"	110	163	ZG1/2"	0.00486	2.11
40	180	1 1/2"	132	203	ZG1/2"	0.00767	3.07
50	200	2"	163	243	ZG1/2"	0.01160	3.91

主要外形和连接尺寸 Main External and Connection Dimension

单位 Unit:mm

NPS	DN	NPT	L	H	H1	B	有效过滤面积 Strainer Area (m ²)	WT (Kg)
in	mm							
SY11C-A150								
3/4	15	1/2"	100	74	99	NPT3/8"	0.00185	0.78
1/2	20	3/4"	110	88	127	NPT1/2"	0.00281	1.23
1	25	1"	130	103	150	NPT1/2"	0.00343	1.43
1 1/4	32	1 1/4"	160	110	163	NPT1/2"	0.00486	2.11
1 1/2	40	1 1/2"	180	132	203	NPT1/2"	0.00767	3.07
2	50	2"	200	163	243	NPT1/2"	0.01160	3.91

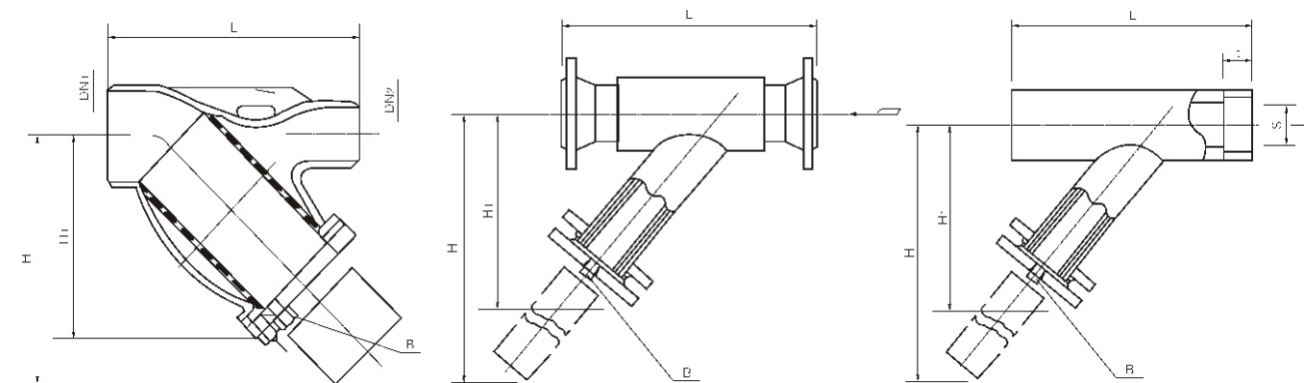

主要外形和连接尺寸 Main External and Connection Dimension

单位 Unit:mm

公称通径DN	L	H	H1	WT(Kg)
SY14C-10 SY14C-16 SY14C-25 SY14C-40 SY14S-10 SY14S-16 SY14S-25 SY14S-40				
15	130	87	120	2.7
20	150	105	150	3.1
25	160	115	176	3.8
32	180	125	193	5.5
40	200	156	237	6.6
50	230	131	270	9.4
65	290	250	370	21.6
80	310	280	430	25.1
100	350	320	488	34.2
125	400	375	547	49.1
150	480	430	622	61.3
200	600	515	741	93.3
250	730	550	880	126

公称通径 DN	L	H	H1	WT(Kg)
SY11C-10 SY11C-16 SY11S-10 SY11S-16				
15	90	75	100	0.8
20	100	90	130	1.2
25	120	105	150	1.4
32	140	110	165	2.1
40	170	135	205	3.1
50	200	165	245	4.0

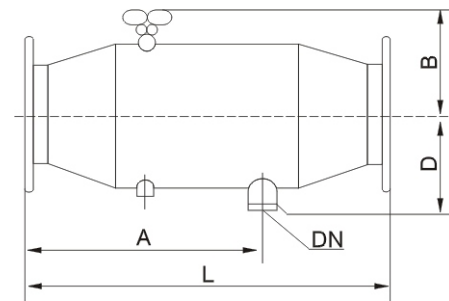

ZPG-I型

工作原理

管道系统在正常工作时，管道内杂物会收集到过滤器网内排污口上，不需拆卸过滤器任何部件来排除杂物，只需打开排污阀即可排污。

①在排污前先把过滤器前阀门，关小流量，进行排污，②排污时把转向阀转向冲洗方向，水从转向阀前部进入，往过滤网外部流过，然后又从过滤网外部进入转向阀后部，杂物全部集中到排污口上，然后再打开排污阀进行排污，起到了最佳自动反冲洗过滤器全部功能。

The working principle

Pipeline system in the normal working hours, the tube will be collected debris filter sewage network, without dismantling the filter to exclude parts of any dirt, just open the sewage to sewage valve.

① sewage in the first pre-filter before the valve, the flow of small clearance, sewage, ② sewage when the valve to wash shift direction from the water valve to the front entry to the flow of external filters, and then filters from the outside To enter the valve at the rear, all the debris on the outfall, and then open the valve for sewage sewage, has played the best automatic backwash filter all the features.

主要外形尺寸 Prime out-form dimensions

型号 Model	L	A	B	C	D
ZPG-I-40	250	180	63	90	15*
ZPG-I-50	255	185	70	100	15*
ZPG-I-65	270	190	83	120	20*
ZPG-I-80	320	225	96	140	25*
ZPG-I-100	350	250	128	180	32*
ZPG-I-125	430	320	162	200	40
ZPG-I-150	525	380	189	230	50
ZPG-I-200	700	520	220	280	65
ZPG-I-250	875	660	255	330	80
ZPG-I-300	1050	790	294	380	100
ZPG-I-350	1200	885	330	450	125
ZPG-I-400	1400	1040	377	480	150
ZPG-I-450	1550	1145	420	500	150
ZPG-I-500	1700	1250	462	580	150
ZPG-I-600	2000	1460	537	650	200
ZPG-I-700	2280	1720	607	700	200
ZPG-I-800	2500	1900	685	820	200
ZPG-I-900	2800	2180	785	880	200
ZPG-I-1000	3120	2470	860	920	250
ZPG-I-1100	3450	2780	915	960	250
ZPG-I-1200	3700	3000	965	1040	250
ZPG-I-1500	4470	3650	1220	1400	250

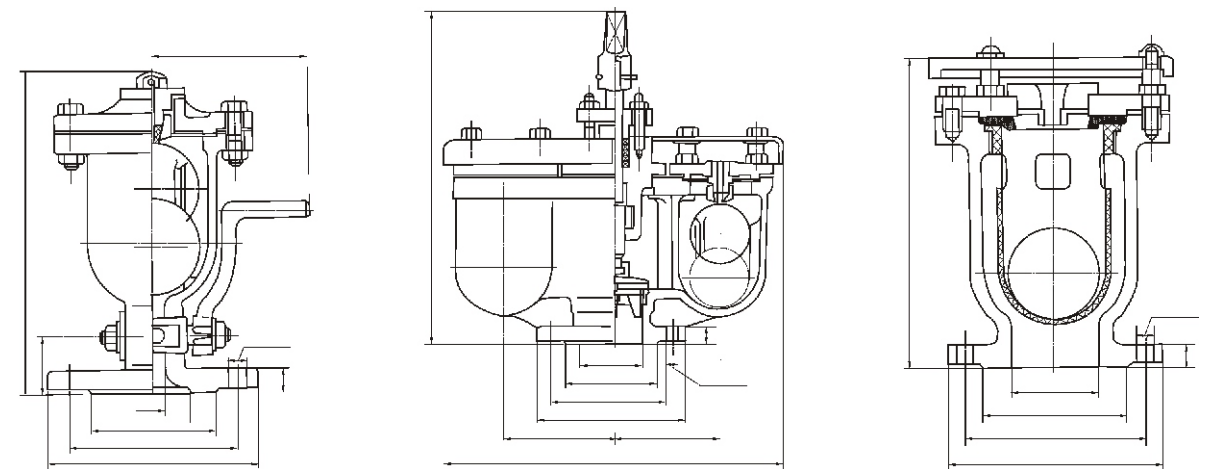

主要外形和连接尺寸 Main External and Connection Dimension

P I -10

单位Unit:mm

公称通径 DN	主要外形和连接尺寸Main External and Connection Dimension								WT (Kg)
	D	D1	D2	b	Z-φd	H	H1	W	
PN1.0MPa									
15	211	168	125	24	4-φ18	284	52	156	10
20	211	168	125	24	4-φ18	303	58	156	20
25	211	168	125	24	4-φ18	331	58	156	25

主要外形和连接尺寸 Main External and Connection Dimension

P II -10

单位Unit:mm

公称通径 DN	主要外形和连接尺寸Main External and Connection Dimension									WT (Kg)
	L	L1	L2	D	D1	D2	b	Z-φd	H	
PN1.0MPa										
50	472	145	145	211	168	125	24	4-φ18	452	56
80	504	157	157	211	168	125	24	4-φ18	459	63
100	548	173	173	238	195	152	25	4-φ18	532	85
150	692	220	220	290	247	204	26	6-φ18	618	145
200	692	220	220	342	299	256	27	6-φ18	700	200

主要外形和连接尺寸 Main External and Connection Dimension

KP(I、II) -10

单位Unit:mm

公称通径 DN	主要外形和连接尺寸Main External and Connection Dimension						WT(Kg)
	D	D1	D2	b	Z-φd	H	
PN1.0MPa							
50	165	125	102	20	4-φ18	420	23
80	200	160	133	22	8-φ18	500	37
100	220	180	158	24	8-φ18	549	48
150	285	240	212	26	8-φ22	615	67
200	340	295	268	28	8-φ22	729	120
50	211	168	125	24	4-φ18	420	25
80	211	168	124	24	4-φ18	500	39
100	238	195	152	25	4-φ18	549	50
150	390	247	204	26	6-φ18	615	69
200	342	299	256	27	6-φ18	729	125

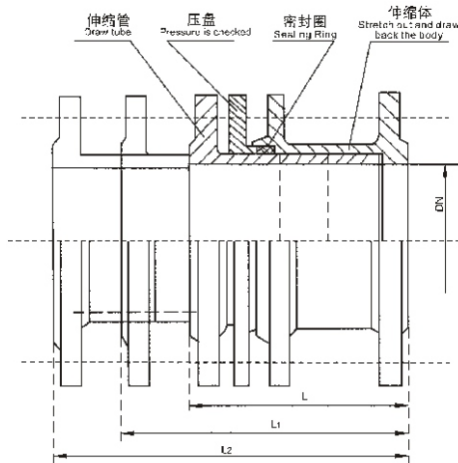

安装数据表 Assemble a data sheet

公称口径DN Nominal diameter	最小长度L Minimum Length	安装长度L1 Assemble Length L1	最小长度L2 Minimum Length L2	伸缩节 Stretch out and draw back festival
40	130	150	170	40
50	135	155	175	40
65	150	175	200	50
80	170	200	230	60
100	170	205	240	70
125	190	225	260	70
150	210	250	290	80
200	220	260	300	80
250	235	275	315	80
300	235	280	325	90
350	250	295	340	90
400	260	305	350	90
450	260	305	350	90
500	270	315	360	90
600	280	330	380	100
700	300	350	400	100
800	330	380	430	100
900	330	380	430	100
1000	350	400	450	100
1200	350	400	450	100
1400	390	445	500	110
1600	410	465	520	110
1800	430	485	540	110
2000	450	510	570	120
2200	480	545	610	130
2400	500	570	640	140
2600	540	615	690	150
2800	580	660	740	160
3000	650	750	850	200

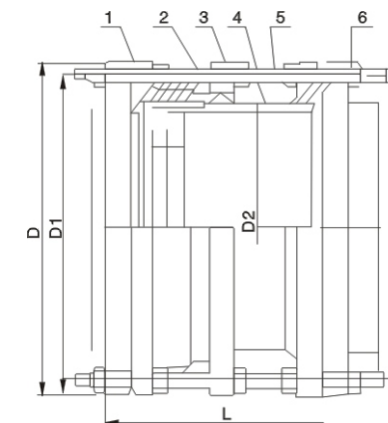

安装数据表 Assemble a data sheet

公称口径 Nominal diameter	管子外径 Dw	外形尺寸		伸缩量	法兰连接尺寸								
		L	L1		0.6MPa			1.0MPa					
					D	D1	n-d0	D	D1	n-d0			
65	76	340	105	50	160	130	4-14	185	145	4-18			
80	89				190	150	4-18	200	160	8-18			
100	108				210	170							
125	133				8-18	240	200	250	210				
150	140					265	225	8-22					
200	219					320	280		340	295			
250	273				370	335	12-18	395	350	12-22			
300	325				350	130	65	440	395	12-22	445	400	-
350	377							490	445		505	460	16-22
400	426							16-22	540	495	565	515	16-26
450	480	590	550	615					565	-			
500	530	645	600	20-22				670	620	20-26			
600	630	755	705	20-26				780	725	20-30			
700	720	860	810	24-26				895	840	24-30			
800	820	975	920	24-30				1015	950	24-33			
900	920	1075	1020	-				1115	1015	28-33			
1000	1020	1175	1120	28-30				1230	1160	28-36			
1200	1220	1405	1340	32-33	1455	1380	32-40						
1400	1420	36-36	1630	1560	1675	1590	36-42						
1500	1520		1730	1660	-	-	-						
1600	1620	1830	1760	40-36	1915	1820	40-48						
1800	1820	2045	1970	44-40	2115	2020	44-48						
2000	2020	2265	2180	48-42	2325	2230	48-48						
2200	2220	2475	2390	52-42	2550	2440	52-56						
2400	2420	2685	2600	56-42	2760	2650	56-56						



JGD型



示意图 Sketch Map:
1、主体 Body
2、内衬 Lining
3、骨架 Shell Sheet
4、法兰 Flange

技术条件 Technical condition

项目 Item	型号 Type	JGD-1	JGD-2	JGD-3
工作压力MPa(kg·f/cm ²) Working pressure		1(10)	1.6(16)	2.5(25)
爆破压力MPa(kg·f/cm ²) Bursting pressure		2(20)	3(30)	4.5(45)
真空度 Vacuity KPa(mmHg)		53.3(400)	86.7(650)	100(750)
适用温度 °C Applicable temperature		-15~+115, 特殊可达(Mannerism)-30~+250		
适用介质 Applicable medium		空气、压缩空气、水、海水、热水、油、酸、碱等 Air, Compresses air, water, sea water, hot weater, acid, etc.		

公称口径、长度、位移数值与法兰主要数据表
Table of main parameters of nominal core diameter, length, displacement and flange

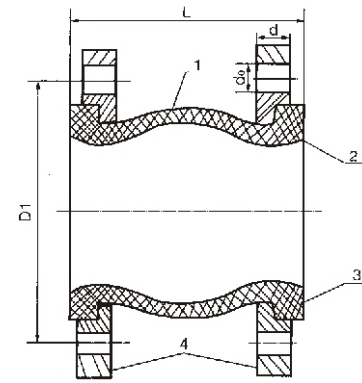
公称口径DN Nominal diameter		长度 L Length (mm)	法兰厚度 Flanae (mm)	螺栓数 of bolt n	螺栓孔直径 Diameler of bolt hole do(mm)	螺栓孔 中心圆直径 center circle do(mm)	轴向位 Axial displacement (mm)		横向位移 Lateral displacement (mm)	偏转角度 Angle of deflection (α1+α2)
(mm)	(in)						伸长Stretch	压缩 Comprwssion		
32	1 1/4	95	16	4	18	100	6	9	9	15°
40	1 1/2	95	18	4	18	110	6	10	9	15°
50	2	105	18	4	18	125	7	10	10	15°
65	2 1/2	115	20	4	18	145	7	13	11	15°
80	3	135	20	8	18	160	8	15	12	15°
100	4	150	22	8	18	180	10	19	13	15°
125	5	165	24	8	18	210	12	19	13	15°
150	6	180	24	8	22	240	12	20	14	15°
200	8	210	24	8	22	295	16	25	22	15°
250	10	230	28	12	22	350	16	25	22	15°
300	12	245	28	12	22	400	16	25	22	15°
350	14	255	28	16	22	460	16	25	22	15°
400	16	255	30	16	26	515	16	25	22	15°
450	18	255	30	20	26	565	16	25	22	15°
500	20	255	32	20	26	620	16	25	22	15°
600	24	260	36	20	26	725	16	25	22	15°
700	28	320	36	24	30	840	16	25	22	15°
800	32	340	36	24	30	950	16	25	22	15°
900	36	370	36	24	30	1050	16	25	22	15°
1000	40	400	36	28	30	1160	18	26	24	15°
1200	48	420	36	32	33	1380	18	26	24	15°

注：1、DN32-1200PN=1MPa 2、DN32-300PN=1.6MPa 3、DN32-300PN=2.5MPa 4、法兰按JB81-59选取5、特殊要求请来函来图订制。6、高层给水使用本产品。管道必须有固定支撑或固定托架。否则产品应安装防拉脱离装置。固定支撑或托架的力必须大于轴向力。否则也应安装防拉脱离装置。
Note: 1. DN32-1200PN=1MPa 2. DN32-300PN=1.6MPa 3. DN32-300PN=2.5MPa 4. Flange is selected according to JB81-59. 5. Special requirements may be satisfied to order by correspondence and graph 6. When using this product for high water supply, the pipeline should be provided with fixed support or bracket, otherwise the product must be fitted with an anti-fall device. The force of fixed support or bracket should be greater than axial force, otherwise an anti-fall device is also needed.

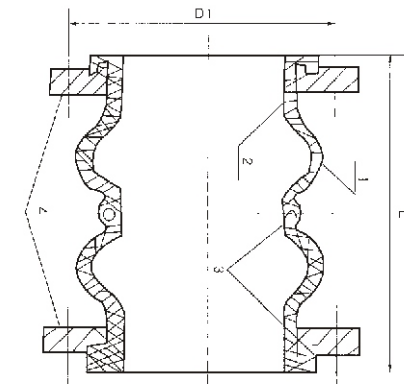

技术条件 Technical condition

项目 Item	型号 Type	200-300(8-12")		50-150(2-6")	
		JGD-A(1)	JGD-A(2)	JGD-A(3)	JGD-A(3)
工作压力MPa(kg·f/cm ²) Working pressure		1(10)	1.6(16)	2.5(25)	2.5(25)
爆破压力MPa(kg·f/cm ²) Bursting pressure		2(20)	3(30)	4.5(45)	4.5(45)
真空度 Vacuity KPa(mmHg)		400(300)	53.3(400)	86.7(650)	86.7(650)
适用温度 °C Applicable temperature		-15~+115, 特殊可达(Mannerism)-30~+250			
适用介质 Applicable medium		空气、压缩空气、水、海水、热水、油、酸、碱等 Air, Compresses air, water, sea water, hot weater, acid, etc.			

公称口径、长度、位移数值与法兰主要数据表
Table of main parameters of nominal core diameter, length, displacement and flange

公称口径DN Nominal diameter		长度 L Length (mm)	法兰厚度 Flanae (mm)	螺栓数 No. of bolt n	螺栓孔直径 Diameler of bolt hole do(mm)	螺栓孔 中心圆直径 center circle do(mm)	轴向位 Axial displacement (mm)		横向位移 Lateral displacement (mm)	偏转角度 Angle of deflection (α1+α2)
(mm)	(in)						伸长Stretch	压缩 Comprwssion		
50	2	165	18	4	17.5	125	30	50	45	35°
65	2 1/2	175	20	4	17.5	145	30	50	45	35°
80	3	175	20	8	17.5	160	35	50	45	35°
100	4	225	22	8	17.5	180	35	50	40	35°
125	5	225	24	8	17.5	210	35	50	40	35°
150	6	225	24	8	22	240	35	50	40	35°
200	8	325	24	8	22	295	35	50	40	35°
250	10	325	28	12	22	350	35	60	35	30°
300	12	325	28	12	22	400	35	60	35	30°

注：特殊要求可来函来图订制。 Note: Special requirements may be satisfied to order by correspondence and graph.

产品防伪查询



不锈钢快装蝶阀

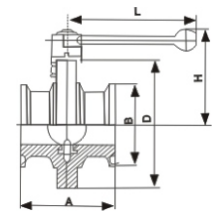

规格(Iso)	A	B	D	L	H
20	66	78	50.5	84	130
25	66	78	50.5	84	130
32	66	78	50.5	84	130
38	70	86	50.5	88	130
51	76	102	64	96	140
63	80	115	77.5	102	150
76	84	128	91	110	150
89	90	139	106	115	160
102	104	155	119	122	160
108	108	159	119	125	160



焊接式蝶阀

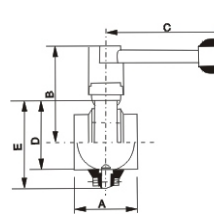

规格(Iso)	A	B	D	L	H
20	66	78	19.05	130	84
25	66	78	25.4	130	84
32	66	78	31.8	130	84
38	70	86	38.1	130	88
51	76	102	50.8	140	96
63	80	115	63.5	150	102
76	84	128	76.1	150	110
89	90	139	88.9	160	115
102	104	155	101.6	160	122
108	108	159	108	160	125



不锈钢三片蝶阀

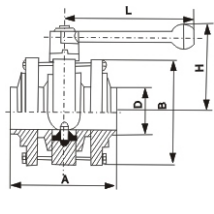

规格(Iso)	A	B	D	L	H
20	100	78	19.05	130	84
25	100	78	25.4	130	84
32	100	78	31.8	130	84
38	100	86	38.1	130	88
51	104	102	50.8	140	96
63	112	115	63.5	150	102
76	112	128	76.1	150	110
89	120	139	88.9	160	115
102	128	155	101.6	160	122
108	128	159	108	160	125



不锈钢卫生级直通式球阀

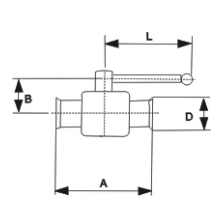

规格(Iso)	DN	D	A		
20	3/4"	50.5	100		
25	1"	50.5	115		
32	1 1/4"	50.5	170		
40	1 1/2"	50.5	150		
50	2"	64	180		
65	2 1/2"	77.5	200		
80	3"	91	220		
100	4"	119	320		



不锈钢卫生级三通式螺纹球阀

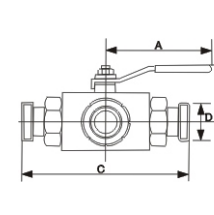

规格(Iso)	DN	D	C		
20	3/4"	36x3	95		
25	1"	40x3	120		
32	1 1/4"	46x3	140		
40	1 1/2"	55x3	170		
50	2"	65x4	190		
65	2 1/2"	80x4	210		
80	3"	90x4	220		
100	4"	115x4	260		

- 一、电话查询：请拨打**95001111**查询
- 二、短信查询：编辑监管码发送至**106695001111**查询
- 三、网站查询：
 - 1、登陆网站 **www.95001111.com**
 - 2、浏览首页，输入监管码，然后点击确定
 - 3、等待查询结果将告知您该产品是否为我公司生产的产品。
- 四、天津市卡尔斯阀门有限公司投诉电话：
022-26333333

Anti-counterfeiting products inquiry

- 1, telephone: Please call **95001111** Query
- 2, SMS queries: regulatory code editor to send text messages to query **106695001111**
- 3, website:
 - ①, visit the Web site **www.95001111.com**
 - ②, visit the home page, enter the code regulation, and then click OK
 - ③, waiting for the results of the inquiry will inform you whether or not the product for our products.
- 4, Kars Valve Co., Ltd. Tianjin complaints:
022-26333333